

LOW-PROFILE FLUORESCENT EMERGENCY BALLAST

1400 LUMENS (TIME DELAY)

INSTALLATION INSTRUCTIONS

IMPORTANT SAFEGUARDS

When using electrical equipment, basic safety precautions should always be followed, including the following:

READ AND FOLLOW ALL SAFETY INSTRUCTIONS

1. Prior to installation, battery connector must be left open to prevent high voltage from being present on output leads (red & yellow). It must be connected only after installation is complete and A.C. Power is supplied to the unit.
2. This unit can operate commonly used linear and compact fluorescent lamps. Please refer to the "lamps list" label on the ballast for specific lamp information.
3. Please ensure the electricity connections conform to the National Electrical Code and local regulations if applicable.
4. To avoid electric shock, please disconnect normal and emergency power supplies, and battery connector of the emergency ballast before servicing.
5. This device is designed for factory or field installation in either the ballast channel, or on top of the fixture, except air handling heated air outlets, sealed and gasketed fixtures, wet or hazardous location fixtures. Do not install this device near gas or electric heaters.
6. AC power source of 120 VAC or 277 VAC is required.
7. The battery in this unit is sealed, and not replaceable in the field. Please contact manufacturer for information on servicing the battery.
8. Do not use accessory equipment that is not recommended by manufacturer. Failure to do so may cause unsafe conditions. Servicing should only be performed by qualified service personnel.
9. Do not use the product for other than it's intended purpose.

CAUTION: Verify that all replacement lamp types marked on the installed luminaire are also identified as suitable for use with this inverter/charger pack.

PLEASE SAVE THESE INSTRUCTIONS

INSTALLATION INSTRUCTIONS

CAUTION: Before installing, make certain the A.C. power is off and the **EMERGENCY BALLAST'S** unit connector is disconnected.

1. MOUNTING THE EMERGENCY BALLAST(BATTERY PACK)

Remove the ballast channel cover. Mount the **EMERGENCY BALLAST** in the ballast channel at least $\frac{1}{2}$ " away from the A.C. ballast(s).

When battery packs are remote mounted, the remote distance can not exceed $\frac{1}{2}$ of the distance from ballast to lamp specified by the A.C. ballast manufacturer. For example, if the A.C. ballast manufacturer recommends no more than 25' remote distance, then the battery packs remote mount distance should not exceed $12\frac{1}{2}$ '. Under no circumstances should the battery pack exceed a distance of 50' from the lamp.

2. WIRING

Refer to the wiring diagrams in the back page for the appropriate wiring of lamp(s) and ballast. Install in accordance with the National Electrical Code and local regulations. For additional wiring diagrams consult Customer Service.

3. INSTALLING THE LED COMBO TEST SWITCH(LCTS)

Recessed Troffer Fixture - Select a convenient location with proper clearance in the ballast cover and drill or punch a $\frac{7}{8}$ " hole ($\frac{1}{2}$ " knockout). Insert the $\frac{7}{8}$ " bushing into the hole. Push the plastic tube through the bushing. Route the leads of the **LCTS** through the plastic tube. Connect the wires from the unit to the **LCTS**(VIOLET to VIOLET, BROWN to BROWN). Push the entire assembly back into the tube until the lens collar rests against the plastic tube. The plastic tube should be adjusted so that the **LCTS** is within $\frac{1}{4}$ " of the fixture lens. The **LCTS** must be visible after installation. Refer to *Illustration 1*.

Strip Fixture - Select a convenient location on the fixture so the **LCTS** can be seen after installation. Allow for proper clearance inside the fixture and drill or punch a $\frac{1}{2}$ " hole. Remove the nut from the **LCTS**. Push the **LCTS** housing into the $\frac{1}{2}$ " hole and secure with the nut. Connect the wires from the **LCTS**(VIOLET to VIOLET, BROWN to BROWN). Refer to *Illustration 2*.

Illustration 1 Recessed Troffer Fixture

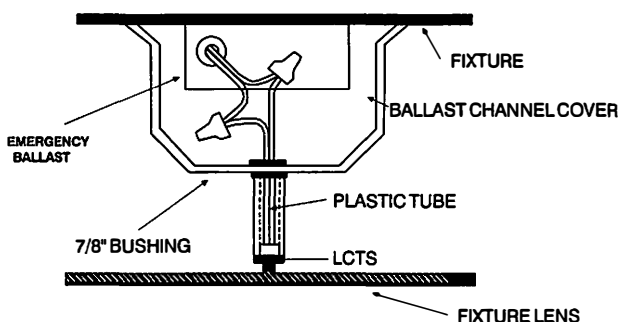
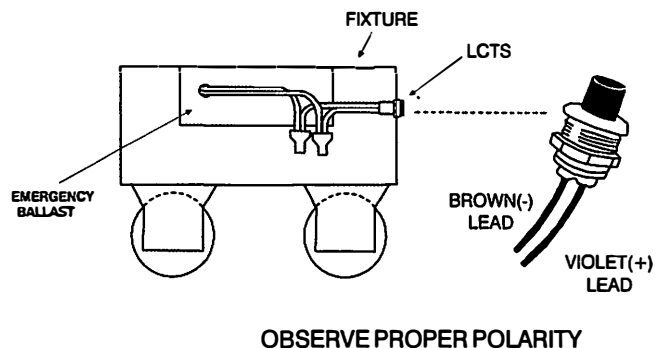

Illustration 2 Strip Fixture



4. WIRING THE A.C. INPUT

- The **EMERGENCY BALLAST** and A.C. ballast **must** be on the same branch circuit
- The **EMERGENCY BALLAST** requires an **unswitched** A.C. power source of either 120 or 277 volts. Select the proper voltage lead and cap the unused lead.
- When the **EMERGENCY BALLAST** is used with a switched fixture, the A.C. Input to the **EMERGENCY BALLAST** must be connected ahead of the fixture switch. Refer to *Illustration 3* for switched and unswitched fixture wiring diagrams.

5. BALLAST WIRING BLOCK DIAGRAM

Illustration 3

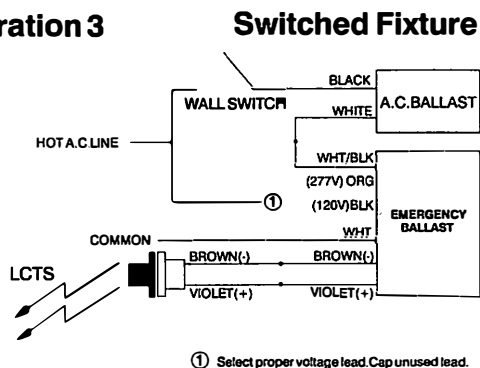

Unswitched Fixture

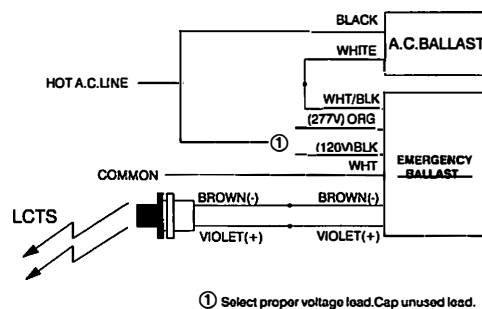

6. LABELS

Attach the appropriate labels adjacent to the LCTS. Annotate Re-lamping label for lamp type and wattage. The 'Caution' and the 'Re-lamping' labels must be on the fixture in a readily visible location to anyone attempting to service the fixture.

7. COMPLETING INSTALLATION

When the installation is complete, switch the A.C. power ON and join the **EMERGENCY BALLAST'S** unit connector.

OPERATION

Normal Mode - A.C. power is present. The A.C. ballast operates the fluorescent lamp(s) as intended. The LCTS will be lit providing a visual indication that the **EMERGENCY BALLAST** is in the standby charging mode.

Emergency Mode - A.C. power fails. The **EMERGENCY BALLAST** senses the A.C. power failure and automatically switches to the *Emergency Mode*. One or two lamps illuminate at reduced output, for a minimum of 90 minutes. When A.C. Power is restored, the **EMERGENCY BALLAST** switches the system back to the *Normal Mode* and resumes battery charging.

TESTING & MAINTENANCE

Pressing the red lens on the LCTS turns off the light on it, interrupts power to the designated A.C. ballast and forces the unit into emergency mode. The emergency lamp (s) is (are) now lit by the **EMERGENCY BALLAST**. On releasing the lens, fixture returns to normal mode after a momentary delay. To simulate a "BLACK OUT" use the circuit breaker to turn off the AC power.

Initial Testing - Allow the unit to charge for approximately 1 hour, then press the LCTS to conduct a short discharge test. Allow a 24 hour charge before conducting a 1½ hour test.

This **EMERGENCY BALLAST** is a maintenance free unit, however, periodic inspection and testing is required. NFPA 101, Life Safety Code, outlines the following schedule:

Monthly - Insure that the LCTS is illuminated. Conduct a 30 second discharge test by depressing the LCTS. One or two lamps should operate at reduced output.

Annually - Insure that the LCTS is illuminated. Conduct a full 1½ hour discharge test. The unit should operate as intended for the duration of the test.

SPECIAL INSTRUCTIONS

The **EMERGENCY BALLAST** can be used with most 2' -4' lamps. Refer to the chart below for the type of lamp(s) operated and the number of lamps to be operated in emergency mode. Contact Customer Service for answers about specific lamps.

*The 6" violet leads provide the lamp selection option. The unit is shipped from the factory with the leads disconnected and capped.

"Written records of testing shall be kept by the owner for inspection by the authority having jurisdiction."

SERVICING SHOULD BE PERFORMED BY QUALIFIED PERSONNEL

TYPICAL WIRING DIAGRAMS

For wiring diagrams of ballasts not shown, consult our Customer Service.

1. ONE LAMP RAPID START BALLAST

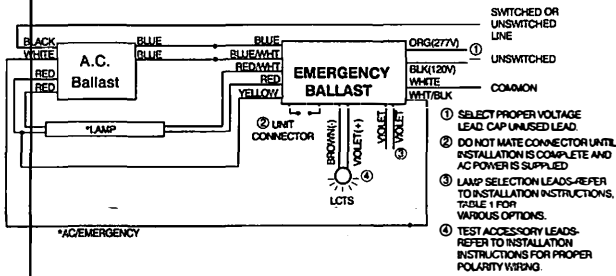

5. ONE LAMP INSTANT START BALLAST

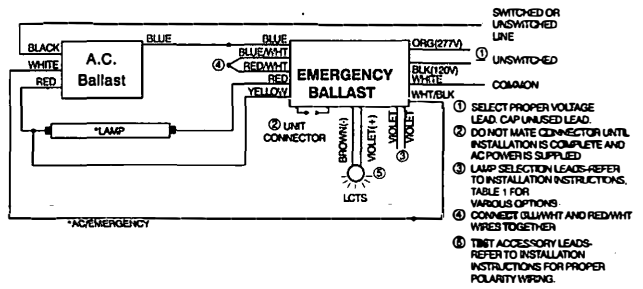

2. TWO LAMP RAPID START BALLAST (TYPE A)

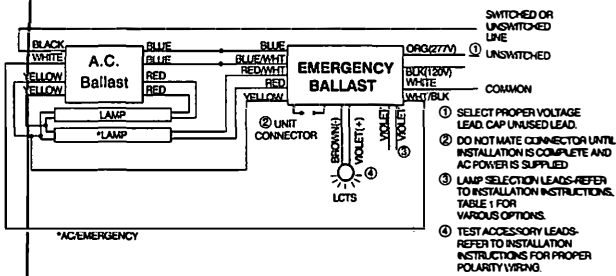

6. TWO LAMP INSTANT START BALLAST

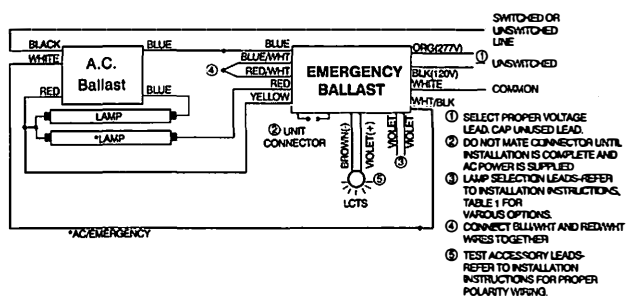

3. TWO LAMP RAPID START BALLAST (TYPE B)

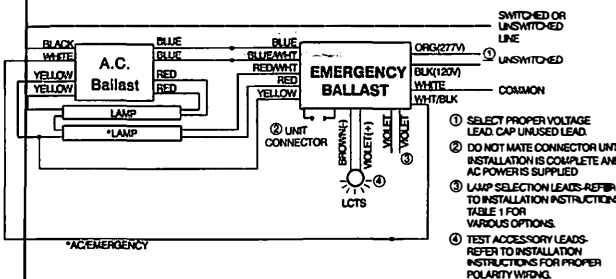

7. THREE LAMP INSTANT START BALLAST

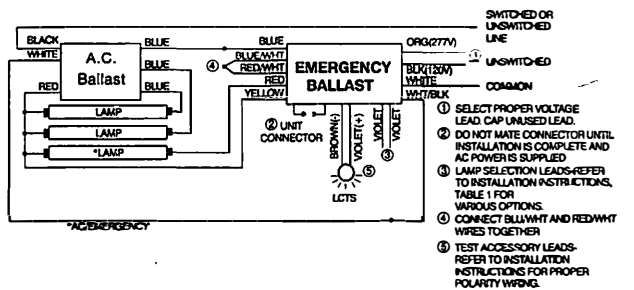

4. THREE LAMP RAPID START BALLAST

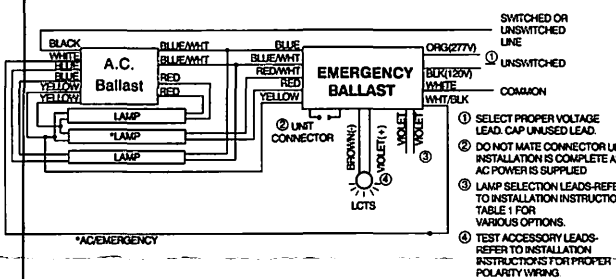

8. FOUR LAMP INSTANT START BALLAST

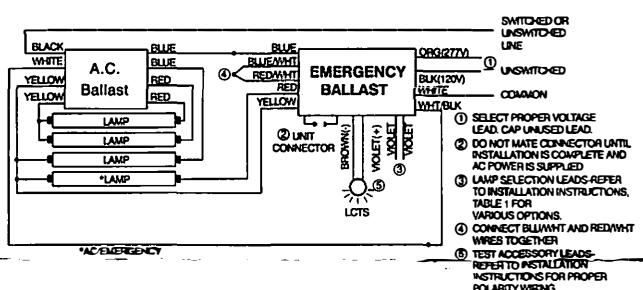

9. TWO LAMP RAPID START BALLAST W/2 LAMP EMERGENCY OPERATION

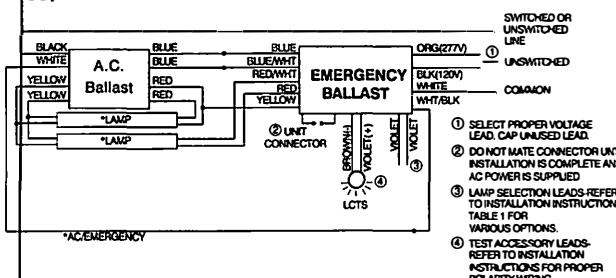

10. TWO LAMP INSTANT START BALLAST W/2 LAMP EMERGENCY OPERATION

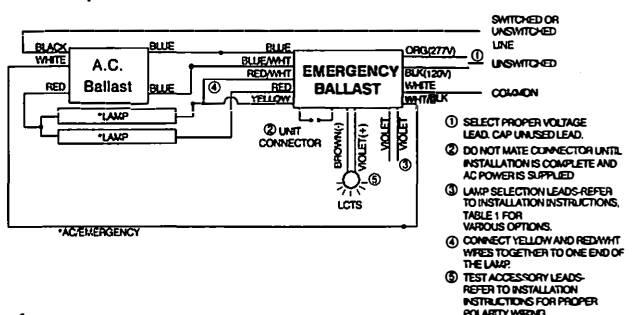

TABLE 1 (FOR BROWN CONNECTOR)

LAMP DIAMETER	BASE TYPE	WATTAGE (LENGTH)	NO.OF LAMPS (EMERGENCY MODE)	BROWN CONNECTOR
T5 (for Emergency-only operation)	SINGLE OR BIPIN	14,21W (2'-3')	1	CONNECTED
T5 (for Emergency-only operation)	SINGLE OR BIPIN	14,21W (2'-3')	2	DISCONNECTED
T5 (for Emergency-only operation)	SINGLE OR BIPIN	28,39,54W (3'-4'-4')	1	CONNECTED
T8	SINGLE OR BIPIN	17,25,32,40W (2'-3'-4'-4'/5')	1	CONNECTED
T8	SINGLE OR BIPIN	17,25,32,40W (2'-3'-4'-4'/5')	2	DISCONNECTED
T8	SINGLE OR BIPIN	59,86W (8')	1	DISCONNECTED
T10	SINGLE OR BIPIN	40W (4')	1	CONNECTED
T10	SINGLE OR BIPIN	40W (4')	2	DISCONNECTED
T12	SINGLE OR BIPIN	20,25,30,34,40W (2'-3'-4'-4'-4')	1	CONNECTED
T12	SINGLE OR BIPIN	20,25,30,34,40W (2'-3'-4'-4'-4')	2	DISCONNECTED
T12	SINGLE OR BIPIN	75,85,95,110,160,215W (5'/8'-8'-8'-8'-8'-8')	1	DISCONNECTED
COMPACT	G24q-1(4pin) G24q-2(4pin) G24q-3(4pin) G24q-3(4pin)	13,18,26,32W	1	CONNECTED
COMPACT	G24q-1(4pin) G24q-2(4pin) G24q-3(4pin) G24q-3(4pin)	13,18,26,32W	2	DISCONNECTED
COMPACT	G24q-4(4pin) G24q-5(4pin)	42,57W	1	DISCONNECTED
LONG COMPACT	2G11(4pin)	18,24,36W	1	CONNECTED
LONG COMPACT	2G11(4pin)	18,24,36W	2	DISCONNECTED
LONG COMPACT	2G11(4pin)	40,50,55W	1	DISCONNECTED
CIRCULAR T9	4-pin	32,40W	1	CONNECTED
CIRCULAR T9	4-pin	32,40W	2	DISCONNECTED
CIRCULAR T5	4-pin	22,40,50W	1	CONNECTED
CIRCULAR T5	4-pin	22,40,50W	2	DISCONNECTED
U-bend T8	Bi-pin	32W	1	CONNECTED
U-bend T8	Bi-pin	32W	2	CONNECTED
U-bend T12	Bi-pin	34,40W	1	CONNECTED
U-bend T12	Bi-pin	34,40W	2	DISCONNECTED